

T100 Series Low Pressure Performance

Capacities

Flow				Pressure	
Model	Max. Input rpm	Max. Flow		Maximum Inlet Pressure	
		gpm	l/min	500 psi (34 bar)	
		@ 1500 psi (103 bar)		Maximum Discharge Pressure	
T100E	450	96.0	366.1	T100E	1500 psi (103 bar)
		@ 1850 psi (128 bar)		T100F	1850 psi (128 bar)
T100F	450	76.5	289.6	T100H	2100 psi (1245 bar)
		@ 2100 psi (145 bar)			
T100H	450	68.0	257.8		

Consult factory when operating below 44 gpm (166.6 l/min).

Maximum Flow at Designated Pressure

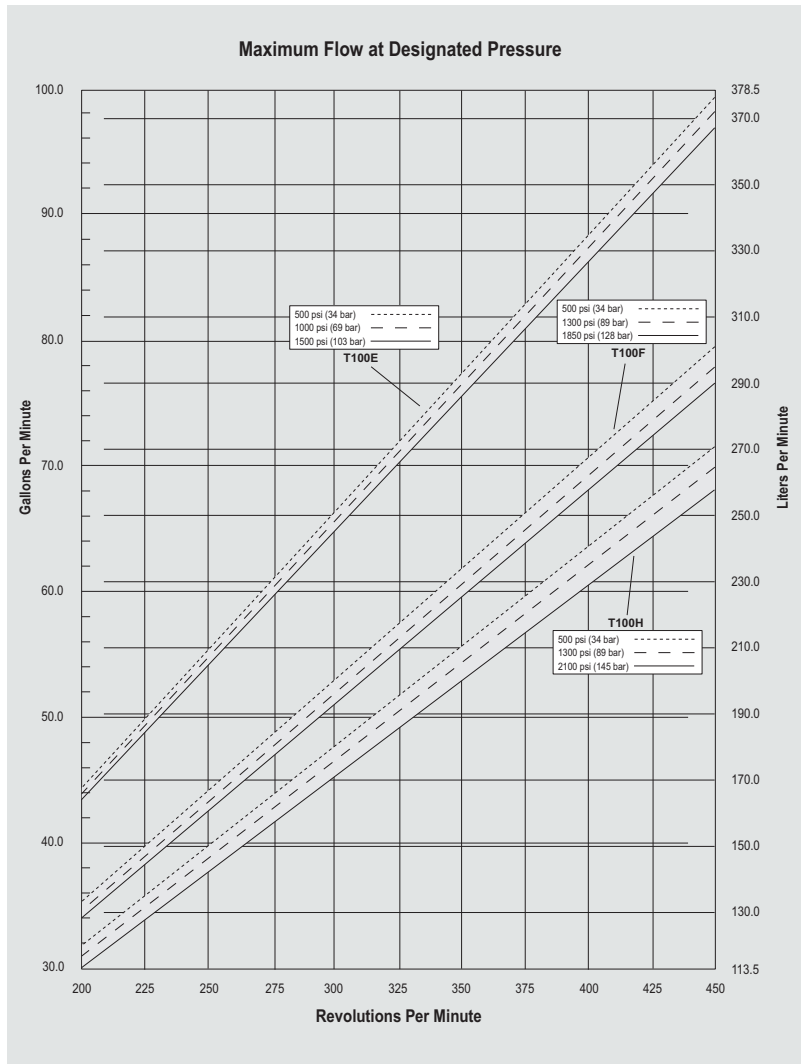

T100 low pressure model shown with Nickel Aluminum Bronze (NAB) manifold. (Also available with Stainless Steel manifold.)

T100 Series Low Pressure Specifications

Flow Capacities

Model	Pressure psi (bar)	rpm	gpm	l/min
T100E	1500 (103)	450	96.0	366.1
T100F	1850 (128)	450	76.5	289.6
T100H	2100 (145)	450	68.0	257.8

Delivery

Pressure psi (bar)	gal/rev	liters/rev
500 (34)	0.221	0.835
1000 (69)	0.218	0.825
1500 (103)	0.215	0.814

rpm

Maximum:	450
Minimum:	200 Consult factory for speeds less than 200 rpm

Maximum Discharge Pressure

Metallic Heads:	T100E	1500 psi (103 bar)
	T100F	1850 psi (128 bar)
	T100H	2100 psi (1245 bar)

Maximum Inlet Pressure

500 psi (34 bar)

Operating Temperature

Maximum:	180 °F (82.2 °C)
Minimum:	40 °F (4.4 °C)

Consult factory for temperatures outside this range

Maximum Solids Size

800 microns

Input Shaft

Left or Right Side

Inlet Ports

3-1/2 inch Class 300 RF ANSI Flange

Discharge Ports

2 inch Class 900 RF ANSI Flange

Shaft Diameter

3 inch (76.2 mm)

Shaft Rotation

Reverse (bi-directional)

Oil Capacity

18 US quarts (17 liters)

10W30 standard-duty oil

Weight

Metallic Heads: 1100 lbs. (499 kg)

Fluid End Materials

Manifold:	Nickel Aluminum Bronze (NAB) 316L Stainless Steel
Diaphragm/Elastomers:	FKM Buna-N
Diaphragm Follower Screw:	316 Stainless Steel
Valve Spring Retainer:	17-7 Stainless Steel 316 SST Hastelloy C
Check Valve Spring:	Elgiloy
Valve Disc/Seat:	Tungsten Carbide 17-4 Stainless Steel Hastelloy C
Outlet Valve Retainer:	316 Stainless Steel
Plug-Outlet Valve Port:	316 Stainless Steel
Inlet Valve Retainer:	316 Stainless Steel

Power End Materials

Crankshaft:	Forged Q&T Alloy Steel
Connecting Rods:	Ductile Iron
Crossheads:	12L14 Steel
Crankcase:	Ductile Iron
Bearings:	Spherical Roller/Journal (main) Steel Backed Babbitt (crankpin) Bronze (wristpin)

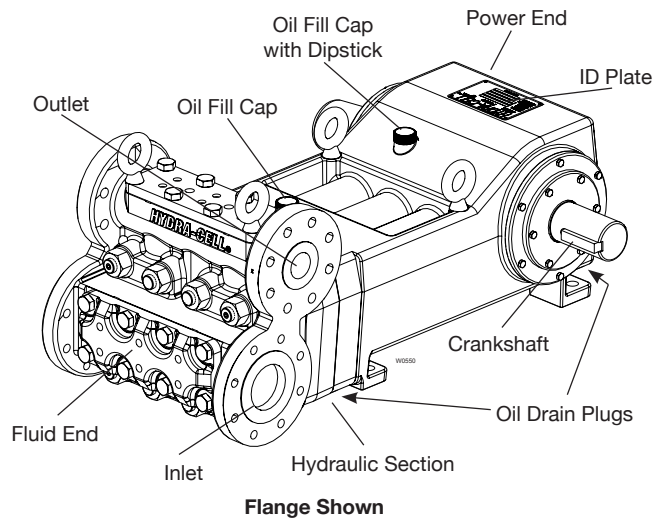

Net Positive Suction Head (NPSHr)

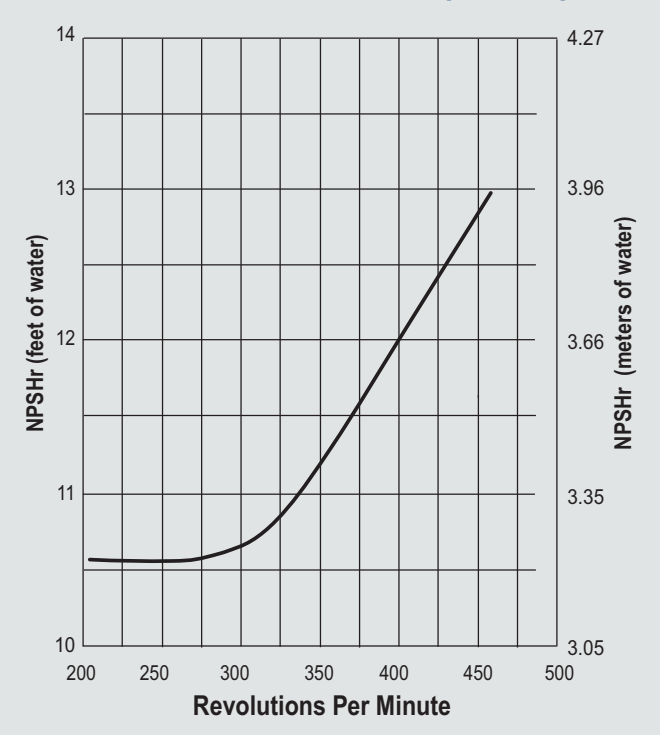

Calculating Required Horsepower (kW)*

$$\frac{\text{gpm} \times \text{psi}}{1,460} = \text{electric motor hp}^*$$

$$\frac{\text{lpm} \times \text{bar}}{511} = \text{electric motor kW}^*$$

* hp (kW) is required application power.

Attention!

When sizing motors with variable speed drives (VFD): It is very important to select a motor and a VFD rated for constant torque inverter duty service and that the motor is rated to meet the torque requirements of the pump throughout desired speed range.

T100 Series Low Pressure Representative Drawings

Flanged Version inches (mm)

Top View

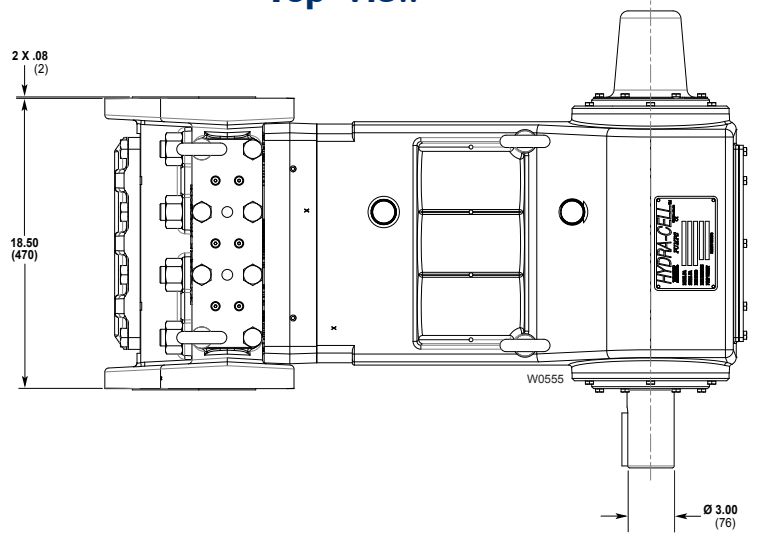

Front View

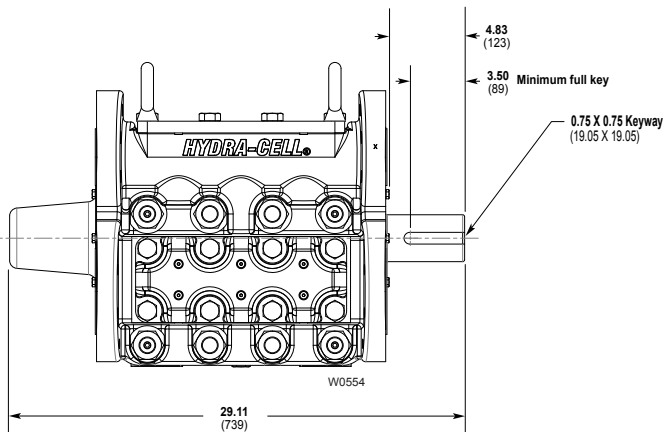

Side View

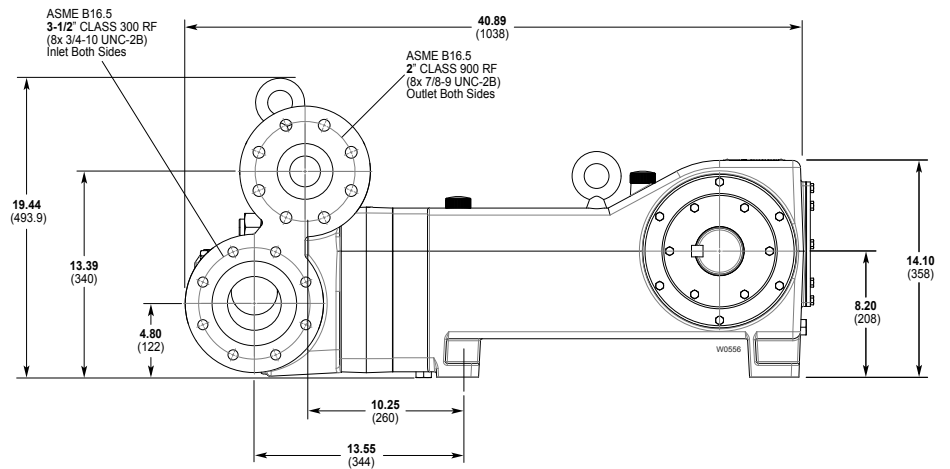

T100 Series Low Pressure How to Order

Ordering Information

1	2	3	4	5	6	7	8	9	10	11	12	13
T	1	0	0									

A complete T100 Series Low Pressure Model Number contains 13 digits including 9 customer-specified design and materials options, for example: T100ERDGHFEHA.

Low Pressure

Digit	Order Code	Description
1-4		Pump Configuration
	T100	Shaft-driven
5		Performance
	E	Max 96.0 gpm (366.1 l/min) @ 1500 psi (103 bar)
	F	Max 76.5 gpm (289.6 l/min) @ 1850 psi (128 bar)
	H	Max 68.0 gpm (257.8 l/min) @ 2100 psi (145 bar)
6		Pump Head Version
	R	ANSI Flange Ports (RF)
7		Pump Head Material
	D	Nickel Aluminum Bronze (NAB)
	S	316L Stainless Steel
8		Diaphragm & O-ring Material
	G	FKM
	T	Buna-N
9		Valve Seat Material
	D	Tungsten Carbide*
	H	17-4 PH Stainless Steel
	T	Hastelloy C
10		Valve Material
	D	Tungsten Carbide*
	F	17-4 PH Stainless Steel
	T	Hastelloy C
11		Valve Springs
	E	Elgiloy
12		Valve Spring Retainers
	H	17-7 Stainless Steel
	S	316 SST
	T	Hastelloy C
13		Hydra-Oil
	A	10W30 standard-duty oil

*Tungsten Carbide valve seat and disc are a matched set and must be purchased together.